

# BUILDING PERMIT APPLICATION – SINGLE CAR DETACHED GARAGE

## HOW TO OBTAIN A BUILDING PERMIT

When a building permit is required, an application must be filed with the Building Department using the following forms. Once submitted with all the necessary documentation, a permit **may** be issued **after** the application has been reviewed to ensure compliance with the Ontario Building Code, the Township Zoning By-law and any other applicable regulation. A plans review document, detailing the deficiencies of your submission, if any, may form part of your building permit. The Chief Building Official is responsible for the issuance of all building permits.

Other Land Use Approval permits may be required from such agencies as the Ministry of Transportation, depending on the nature of the project and the specific location of the site.

Building permit fees are listed in **Schedule “A” of By-Law 3759-2025**. All required **fees** must be paid before the permit can be issued.

**Please follow each of the steps below. Should you feel that one of the steps is not required, please contact the Chief Building Official for confirmation.**

## **Step 1: Authorization for Applicant to Act as Agent**

If someone else is applying for a building permit on your behalf or will be discussing your project with the Chief Building Official on your behalf, the following form will need to be signed by you – the landowner – and submitted with your application.

### Agent for Registered Landowner

## **Step 2: Building Permit Application**

All applicants must complete, sign and date the Application for a Permit to Construct or Demolish as well as the Roles & Responsibilities Declaration Form, and the Site & Drainage Plan Form.

The completed application form must be accompanied by the following:

1. **A deed** may be required indicating the name of the **current registered owner** of the property for which the permit is to be issued.
2. **A site plan** showing the **location of all existing and proposed buildings or additions, any hydro lines, water courses, pipelines, railway tracks and wells or septic systems and leaching beds** on the lot in relation to the property
3. Provide a reasonable and clear **plan showing water drainage** and run off, satisfactory to the Municipal Drainage Superintendent or Designate.

4. **Drawings (2 Sets)** of the proposed works, **fully dimensioned and showing sufficient detail** in order to determine compliance with the building code and any other applicable *\*One set of drawings are to be printed, the 2<sup>nd</sup> set is to be submitted in PDF format by email to [kmorrell@augusta.ca](mailto:kmorrell@augusta.ca).*
5. **Truss layout, truss package and joist system layout** must be submitted to the building department prior to the framing inspection request.

### **Step 3: Complete the Building Guide**

The Colorado Chapter of the International Code Council has an excellent, simple [form](#) for applicants to complete which explains in detail the information required by the Chief Building Official to issue your building permit. Please complete this [form](#) and submit it with the rest of your application.

**If you have any questions regarding any part of this process, please call or email the Chief Building Official, Karen Morrell at 613-925-4231 ext. 106, [kmorrell@augusta.ca](mailto:kmorrell@augusta.ca).**

**SCHEDULE A  
BY-LAW 3759-2025**

**BUILDING**

ITEM	FEE	NOTES
Compliance Letter	\$100.00	
Fast Tracked Compliance Letter	\$150.00	Within 48 hours
Occupancy Permit, (new construction)	\$95.00	
Residential Buildings	1.00/sq ft	
Partially finished basement, non-living space	\$.85/sq ft	Excludes building services mechanical area
Accessory Buildings	\$.50/sq ft	
Solar Panels	\$.30/sq ft	Plus, engineering report on structural adequacy of building
Designated Structures	\$10.00 per \$1,000.00 of evaluation cost	
Agricultural Use Structures	\$.25/sq ft	Max. \$750.00 Building up to 20,000 sq ft
Agriculture Use Structures	\$.05/sq ft	Building over 20,000 sq ft
Commercial/Industrial	\$.40/sq ft	
Demolition Permit	\$110.00	
Pool Permits	\$95.00	Pool only
Tents	\$95.00	Greater than 646 sq ft
Decks, pool decks, porches, gazebos	\$.50/sq ft	
Plumbing	\$11.00/fixture	
Woodstove permits	\$95.00	Does not include WETT
Conditional Permit	\$110.00	
Re-inspections/Plan re-examination	\$95.00	2nd + inspections/ 2nd + examinations
Change of use permit	\$.35/sq ft	
Transfer or Renewal permit	\$95.00	With no changes
Insulation/vapour barrier retrofit	\$95.00	
Hydronic heating or Radon Piping	\$95.00	
Misc. inspections	\$95.00	
Revision permit	\$95.00	Based on new construction fees or min amount.
Revocation of Permit	65% of permit value	Minimum \$95
Building without a permit	Double the cost of the Permit	
Refundable deposit, new residential	\$500.00	After final inspection Deductions may apply

Non-refundable deposit	\$95.00	Applied to permit cost
Orders issued under the Building Code Act	\$250.00	
Inspections required beyond two years from date of permit issuance	\$250.00	
Alternative Solutions	\$1,000.00	Plus, any third-party review costs.

Minimum fee \$95.00

The amount of fees that may be refunded shall be a percentage of the fees payable under this by-law, as follows:

- (a) 80% of the fees if administrative functions only have been performed;
- (b) 70% of the fees if administrative and zoning functions only have been performed;
- (c) 45% of the fees if administrative, zoning and plan examination functions have been performed;
- (d) 35% of the fees if the permit had been issued and no field inspections have been performed subsequent to permit issuance;
- (e) 5% of the fees shall additionally be deducted for each field inspections have been performed after the permit has been issued;
- (f) Notwithstanding Section 1 above, no refund shall be made of an amount less than \$25.00;
- (g) Refunds shall not be granted unless the owner requests a refund in writing to the CBO within six (6) months of issue of the permit; and
- (h) Requests for partial refunds due to changes in the estimated construction values must be submitted in writing to the CBO within six (6) months of substantial completion of the project.

**"SCHEDULE "B"  
OF BY-LAW 3413**

**RESPECTING PLANS OR WORKING DRAWINGS**

List of Plans or Working Drawings (2 sets required) to accompany application for permits.

- 1) The Site Plan
- 2) Floor Plans
- 3) Foundation Plans
- 4) Framing Plans
- 5) Roof Plans/Truss Plans
- 6) Energy Efficiency Design Summary
- 7) Reflected Ceiling Plans
- 8) Sections and Details
- 9) Building Elevations
- 10) Electrical Drawings
- 11) Heating, Ventilations and Air Conditioning Drawings
- 12) Plumbing Drawings

**NOTE:** The Chief Building Official may specify that not all the above mentioned plans are required to accompany an application for permit.



**AUGUSTA TOWNSHIP**  
**3560 County Road 26**  
**Prescott, ON K0E 1T0**  
**Phone: 613-925-4231 Fax: 613-925-3499**

## **AUTHORIZATION FOR AN APPLICANT TO ACT AS AN AGENT FOR THE REGISTERED LANDOWNER**

I, \_\_\_\_\_, being the legal owner of the  
property located at (Civic address) \_\_\_\_\_,  
in the Township of Augusta authorize \_\_\_\_\_  
whose phone number and mailing address is \_\_\_\_\_  
\_\_\_\_\_

to Act as an agent on my behalf.

\_\_\_\_\_  
Signature of Registered Landowner

# Application for a Permit to Construct or Demolish

This form is authorized under subsection 8(1.1) of the *Building Code Act, 1992*

<b>For use by Principal Authority</b>				
Application number:		Permit number (if different):		
Date received:		Roll number:		
Application submitted to: _____ (Name of municipality, upper-tier municipality, board of health or conservation authority)				
<b>A. Project information</b>				
Building number, street name		Unit number	Lot/con.	
Municipality	Postal code	Plan number/other description		
Project value est. \$		Area of work (m <sup>2</sup> )		
<b>B. Purpose of application</b>				
New construction	Addition to an existing building	Alteration/repair	Demolition	Conditional Permit
Proposed use of building		Current use of building		
Description of proposed work				
<b>C. Applicant</b>				
		Applicant is:	Owner or	Authorized agent of owner
Last name	First name	Corporation or partnership		
Street address		Unit number	Lot/con.	
Municipality	Postal code	Province	E-mail	
Telephone number	Fax		Cell number	
<b>D. Owner (if different from applicant)</b>				
Last name	First name	Corporation or partnership		
Street address		Unit number	Lot/con.	
Municipality	Postal code	Province	E-mail	
Telephone number	Fax		Cell number	

<b>E. Builder (if known)</b>				
Last name		First name	Corporation or partnership (if applicable)	
Street address			Unit number	Lot/con.
Municipality		Postal code	Province	E-mail
Telephone number		Fax		Cell number
<b>F. New home construction licensing requirement</b>				
i. Is the proposed construction for a new home as defined in the <i>New Home Construction Licensing Act, 2017</i> ? If no, go to section G.			Yes	No
ii. Is a licence required under the <i>New Home Construction Licensing Act, 2017</i> ?			Yes	No
iii. If yes to (ii) provide licence number(s): _____				
<b>G. Required Schedules</b>				
i) Attach Schedule 1 for each individual who reviews and takes responsibility for design activities.				
ii) Attach Schedule 2 where application is to construct on-site, install or repair a sewage system.				
<b>H. Completeness and compliance with applicable law</b>				
i) This application meets all the requirements of clauses 1.3.1.3 (5) (a) to (d) of Division C of the Building Code (the application is made in the correct form and by the owner or authorized agent, all applicable fields have been completed on the application and required schedules, and all required schedules are submitted). Payment has been made of all fees that are required, under the applicable by-law, resolution or regulation made under clause 7(1)(c) of the <i>Building Code Act, 1992</i> , to be paid when the application is made.			Yes	No
ii) This application is accompanied by the plans and specifications prescribed by the applicable by-law, resolution or regulation made under clause 7(1)(b) of the <i>Building Code Act, 1992</i> .			Yes	No
iii) This application is accompanied by the information and documents prescribed by the applicable by-law, resolution or regulation made under clause 7(1)(b) of the <i>Building Code Act, 1992</i> which enable the chief building official to determine whether the proposed building, construction or demolition will contravene any applicable law.			Yes	No
iv) The proposed building, construction or demolition will not contravene any applicable law.			Yes	No
<b>I. Declaration of applicant</b>				
I _____ declare that: (print name)				
1. The information contained in this application, attached schedules, attached plans and specifications, and other attached documentation is true to the best of my knowledge.				
2. If the owner is a corporation or partnership, I have the authority to bind the corporation or partnership.				
_____		_____		
Date		Signature of applicant		

Personal information contained in this form and schedules is collected under the authority of subsection 8(1.1) of the *Building Code Act, 1992*, and will be used in the administration and enforcement of the *Building Code Act, 1992*. Questions about the collection of personal information may be addressed to: a) the Chief Building Official of the municipality or upper-tier municipality to which this application is being made, or, b) the inspector having the powers and duties of a chief building official in relation to sewage systems or plumbing for an upper-tier municipality, board of health or conservation authority to whom this application is made, or, c) Director, Building and Development Branch, Ministry of Municipal Affairs and Housing 777 Bay St., 12th Floor. Toronto, ON M7A 2J3 (416) 585-6666.

## Schedule 1: Designer Information

Use one form for each individual who reviews and takes responsibility for design activities with respect to the project.

<b>A. Project Information</b>			
Building number, street name	Unit no.	Lot/con.	
Municipality	Postal code	Plan number/ other description	
<b>B. Individual who reviews and takes responsibility for design activities</b>			
Name	Firm		
Street address	Unit no.	Lot/con.	
Municipality	Postal code	Province	E-mail
Telephone number	Fax number		Cell number
<b>C. Design activities undertaken by individual identified in Section B. [Building Code Table 3.5.2.1. of Division C]</b>			
House	HVAC – House	Building Structural	
Small Buildings	Building Services	Plumbing – House	
Large Buildings	Detection, Lighting and Power	Plumbing – All Buildings	
Complex Buildings	Fire Protection	On-site Sewage Systems	
Description of designer's work			
<b>D. Declaration of Designer</b>			
<p>I _____ declare that (choose one as appropriate):</p> <p style="text-align: center;">(print name)</p> <p>I review and take responsibility for the design work on behalf of a firm registered under subsection 3.2.4. of Division C, of the Building Code. I am qualified, and the firm is registered, in the appropriate classes/categories.</p> <p>Individual BCIN: _____</p> <p>Firm BCIN: _____</p> <p>I review and take responsibility for the design and am qualified in the appropriate category as an “other designer” under subsection 3.2.5. of Division C, of the Building Code.</p> <p>Individual BCIN: _____</p> <p>Basis for exemption from registration: _____</p> <p>The design work is exempt from the registration and qualification requirements of the Building Code.</p> <p>Basis for exemption from registration and qualification: _____</p> <p>I certify that:</p> <ol style="list-style-type: none"> <li>1. The information contained in this schedule is true to the best of my knowledge.</li> <li>2. I have submitted this application with the knowledge and consent of the firm.</li> </ol> <p style="text-align: center;">             _____              Date <span style="margin-left: 200px;">Signature of Designer</span> </p>			

**NOTE:**

1. For the purposes of this form, “individual” means the “person” referred to in Clause 3.2.4.7(1) (c). of Division C, Article 3.2.5.1. of Division C, and all other persons who are exempt from qualification under Subsections 3.2.4. and 3.2.5. of Division C.
2. Schedule 1 is not required to be completed by a holder of a license, temporary license, or a certificate of practice, issued by the Ontario Association of Architects. Schedule 1 is also not required to be completed by a holder of a license to practise, a limited license to practise, or a certificate of authorization, issued by the Professional Engineers Ontario.

## Schedule 2: Sewage System Installer Information

<b>A. Project Information</b>			
Building number, street name		Unit number	Lot/con.
Municipality	Postal code	Plan number/ other description	
<b>B. Sewage system installer</b>			
Is the installer of the sewage system engaged in the business of constructing on-site, installing, repairing, servicing, cleaning or emptying sewage systems, in accordance with Building Code Article 3.3.1.1, Division C?			
Yes (Continue to Section C)	No (Continue to Section E)	Installer unknown at time of application (Continue to Section E)	
<b>C. Registered installer information (where answer to B is "Yes")</b>			
Name		BCIN	
Street address		Unit number	Lot/con.
Municipality	Postal code	Province	E-mail
Telephone number	Fax	Cell number	
<b>D. Qualified supervisor information (where answer to section B is "Yes")</b>			
Name of qualified supervisor(s)		Building Code Identification Number (BCIN)	
<b>E. Declaration of Applicant:</b>			
<p>I _____ declare that:</p> <p style="text-align: center;">(print name)</p> <p>I am the applicant for the permit to construct the sewage system. If the installer is unknown at time of application, I shall submit a new Schedule 2 prior to construction when the installer is known;</p> <p><u>OR</u></p> <p>I am the holder of the permit to construct the sewage system, and am submitting a new Schedule 2, now that the installer is known.</p> <p>I certify that:</p> <ol style="list-style-type: none"> <li>1. The information contained in this schedule is true to the best of my knowledge.</li> <li>2. If the owner is a corporation or partnership, I have the authority to bind the corporation or partnership.</li> </ol> <p>_____</p> <p style="text-align: center;">Date <span style="margin-left: 200px;">Signature of applicant</span></p>			



**Application submitted to:** The Corporation of the Township of Augusta  
3560 County Rd. 26, Prescott, ON, K0E 1T0  
T 613-925-4231 F 613-925-3499  
[www.augusta.ca](http://www.augusta.ca)

## **Roles and Responsibilities of the Builder or to Whom a Permit is Issued**

- Comply with BCA/OBC; 8.(11)
- Complete applications with required info.; BCA 7., 8.(2e), [C]1.3.1.3.(5)
- Obtain permit prior to construction; 1.(1)
- Obtain permit prior to Change of Use unless exempt by [C]1.3., BCA1.(2), 8.(1), 34. (1)
- Post permit; BCA 34.(1), [C]1.3.2.1(1)
- Copy of drawings on site; BCA 34.(1), [C]1.3.2.2.(1a.b)
- Notify CBO of changes; BCA 8.(12)
- Adhere to plans, specs; BCA 8.(13)
- Fences to enclose site; BCA 7.(1i,j)
- Notify on stages of construction; BCA 10.(2), [C]1.3.5.1.(2)
- Occupy unfinished bldg. after inspection; BCA [C]1.3.3.1.(2), 1.3.3.2.(1)
- Provide as constructed plans; [C]1.3.6., BCA 7.(1g)
- Not hinder but assist; BCA 19.
- Obey Stop Work Order; BCA 14.(4)
- Respect posted orders; BCA 20.1.

Before the work starts ensure that all contractors have WSIB clearance numbers (1-800-387-0750) The law has changed. Failing to register with the WSIB by January 2014 and working without a clearance number means penalties and significant fines for contractors and those who hire them. [www.wsib.on.ca](http://www.wsib.on.ca)

- Minimum clearance to hydro lines or poles is 5 meters horizontally or vertically. Electrical Safety Authority (ESA) 1-877-372-7233
- Minimum clearance to railway tracks are as described in section 6.38 and 6.42.1 of Zoning By-Law #2965.
- Canadian National Railway runs through Augusta Township. (CNR) 1-888-888-5909
- Minimum clearance to pipelines is 30 meters from the pipeline right of way. Pipeline Public Awareness 1-855-458-6715
- New residential development shall be setback a minimum distance in accordance with MDS calculations as per section 6.42.3. of Zoning By-Law #2965.

Call Before You Dig – It's Free. In Ontario: 1-800-400-2255 or  
[www.clickbeforeyoudig.com](http://www.clickbeforeyoudig.com) Ontario One Call: 1-800-400-2255.  
[www.on1call.com](http://www.on1call.com)

Pipeline Emergency: 1-888-982-7222  
Pipeline Landowner Inquiries: 1-866-372-1601



**Application submitted to:** The Corporation of the Township of Augusta  
3560 County Rd. 26, Prescott, ON, K0E 1T0  
T 613-925-4231 F 613-925-3499  
[www.augusta.ca](http://www.augusta.ca)

**DECLARATION OF BUILDER, APPLICANT OR OWNER**

I, \_\_\_\_\_ declare that I have read and understood  
the information and agree to abide by these roles and responsibilities listed above.

\_\_\_\_\_  
Signature

\_\_\_\_\_  
Date





**Application submitted to:** The Corporation of the Township of Augusta  
3560 County Rd. 26, Prescott, ON, K0E 1T0  
T 613-925-4231 F 613-925-3499  
[www.augusta.ca](http://www.augusta.ca)

NOTES:



# Building Guide

Colorado Chapter of the International Code Council

## Single Family Residential One Story Detached Garage

### How to Use this Guide

Check with your jurisdiction regarding type of submittal (paper or electronic) and additional requirements. Draw to scale and complete the following (*hint: use graph paper with ¼" squares. Example: ¼" = 1'*).

**1 Complete this Building Guide** by filling in the blanks on page two and four, and indicating which construction details will be used.

**2 Provide 2 Plot Plans** (site plan) showing dimensions of your project and its relationship to existing buildings or structures on the property and the distance to existing property lines, drawn to scale. See page3.

**3 Fill out a building permit application.**

The majority of permit applications are processed with little delay. The submitted documents will help determine if the project is in compliance with building safety codes, zoning ordinances and other applicable laws.

The Colorado Chapter of the International Code Council is a professional organization seeking to promote the public health, safety and welfare to building construction. We appreciate your feedback and suggestions please write to the Colorado Chapter of the International Code Council, P.O. Box 961, Arvada, CO 80001. This building guide can be found on the Colorado Chapter of the International Code Council website at:  
<http://www.coloradochaptericc.org>

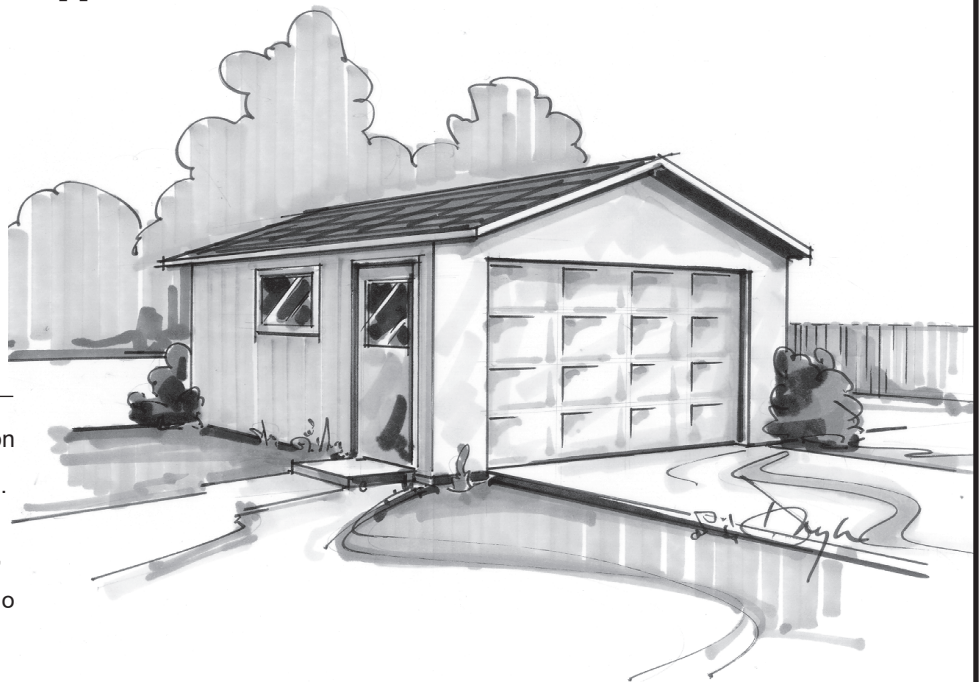

This handout was developed by the Colorado Chapter of the International Code Council as a basic plan submittal under the 2018 International Residential Code. It is not intended to cover all circumstances. Check with your Department of Building Safety for additional requirements.

# Single Family Residential One Story Detached Garage

## Directions

1. Fill in the blanks on pages 2 and 4 with dimensions and materials which will be used to build the structure. Please print legibly.

Address: \_\_\_\_\_  
 \_\_\_\_\_

2. Indicate in the check boxes on page 4 which details from page 5 will be used.

Note: Heated garages will require insulation, such as ceilings, walls, and foundation.

## Floor Plan

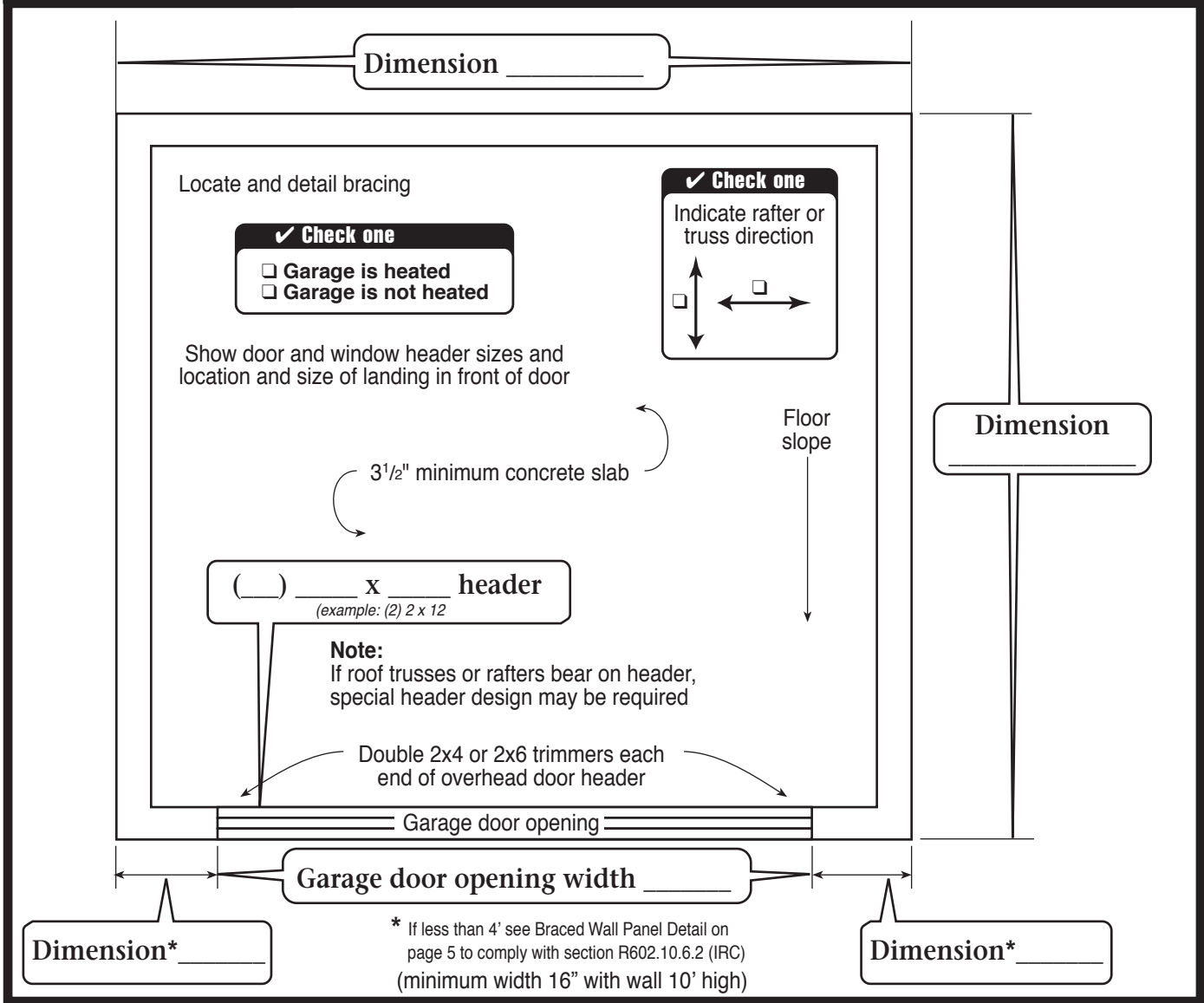

This handout was developed by the Colorado Chapter of the International Code Council as a basic plan submittal under the 2018 International Residential Code. It is not intended to cover all circumstances. Check with your Department of Building Safety for additional requirements.

\_\_\_\_\_

# Single Family Residential One Story Detached Garage

## Site Plan Example

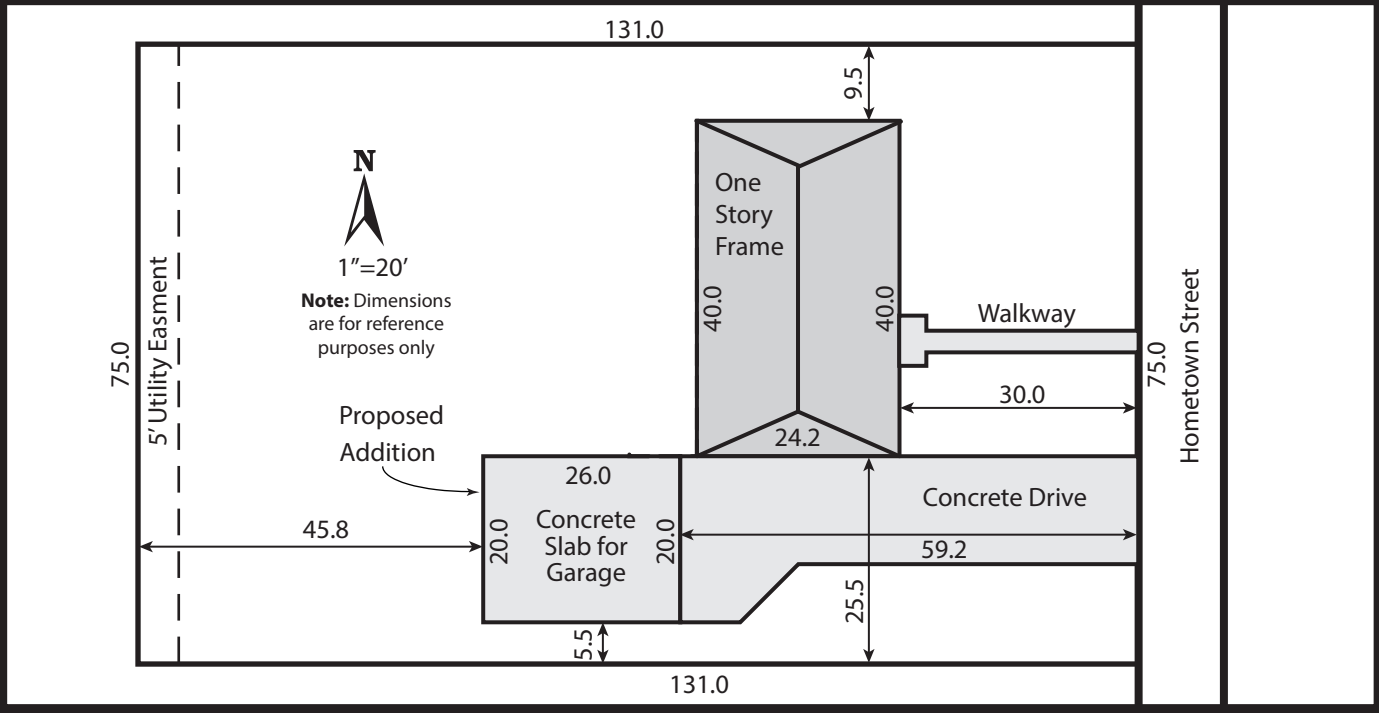

This handout was developed by the Colorado Chapter of the International Code Council as a basic plan submittal under the 2018 International Residential Code. It is not intended to cover all circumstances. Check with your Department of Building Safety for additional requirements.



# Single Family Residential One Story Detached Garage

Note: For roofs with slopes less than 4:12, follow manufacturer's instructions for low slope application of roofing material.

Truss or 2x \_\_\_\_\_ rafters spaced \_\_\_\_\_" O.C.  
*(example: Put checkmark in box -or- 2 x 10 Rafters Spaced 24")*

Minimum 1x \_\_\_\_\_ ridge board  
*(example: 1 x 12)*

Sheathing \_\_\_\_\_  
*(example: 1/2" exterior plywood)*

Roof covering \_\_\_\_\_  
*(example: Class A 3 tab shingles)*

Underlayment \_\_\_\_\_  
*(example: 1 layer #15 felt)*

12 pitch \_\_\_\_\_

Ceiling Insulation \_\_\_\_\_  
*(If heated - example: R-38)*

2x \_\_\_\_\_ ceiling joists @ \_\_\_\_\_ O.C.  
*(example: 2 x 8 @ 24" O.C.)*

Double 2x \_\_\_\_\_ top plate  
*(example: 2 x 6)*

Span \_\_\_\_\_  
*(example: 23' 5")*

Ceiling height \_\_\_\_\_  
*(example: 8')*

Siding \_\_\_\_\_  
*(example: lap or T-111)*

Wall sheathing \_\_\_\_\_  
*(example: 1/2" exterior plywood)*

2x \_\_\_\_\_ studs @ \_\_\_\_\_ O.C.  
*(example: 2 x 6 @ 24" O.C.)*

Cont. 2x \_\_\_\_\_ sill plate  
*(example: 2 x 6 decay resistant)*

Wall Insulation \_\_\_\_\_  
*(If heated - example: R-20 Fiberglass Batts)*

Foundation Insulation \_\_\_\_\_  
*(If heated - example: R-10)*

Footing size \_\_\_\_\_ x \_\_\_\_\_  
*(example: 8" x 16")*

## Building Section

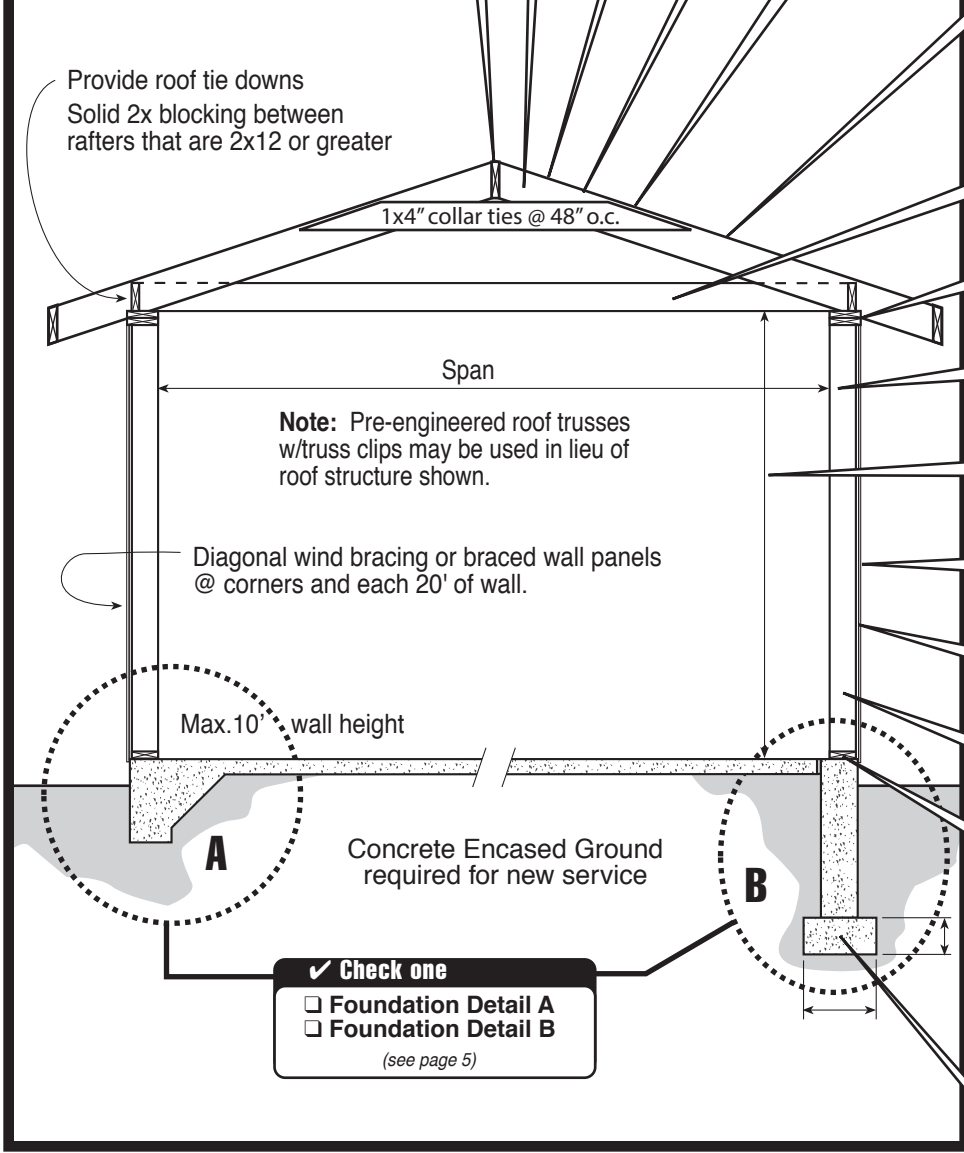

Check one

Foundation Detail A

Foundation Detail B

*(see page 5)*

This handout was developed by the Colorado Chapter of the International Code Council as a basic plan submittal under the 2018 International Residential Code. It is not intended to cover all circumstances. Check with your Department of Building Safety for additional requirements.



# Single Family Residential One Story Detached Garage

## Foundation Detail A

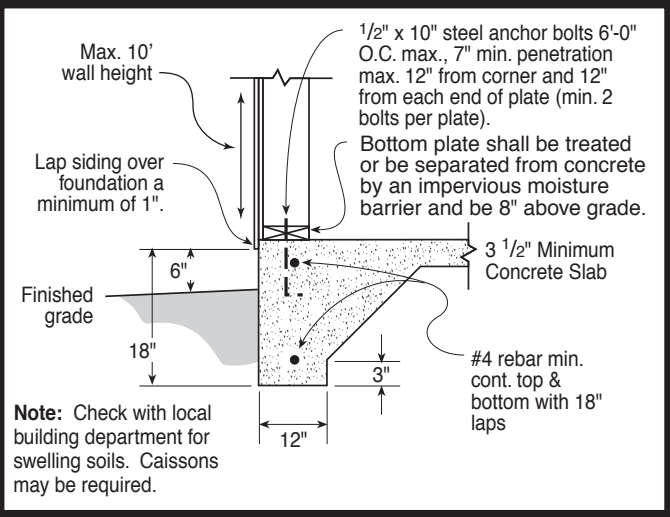

## Foundation Detail B

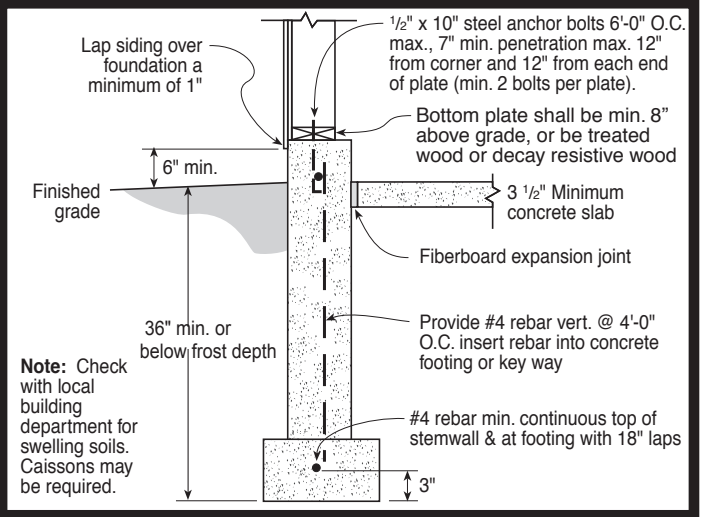

## Braced Wall Panel Detail figure 602.10.6.2

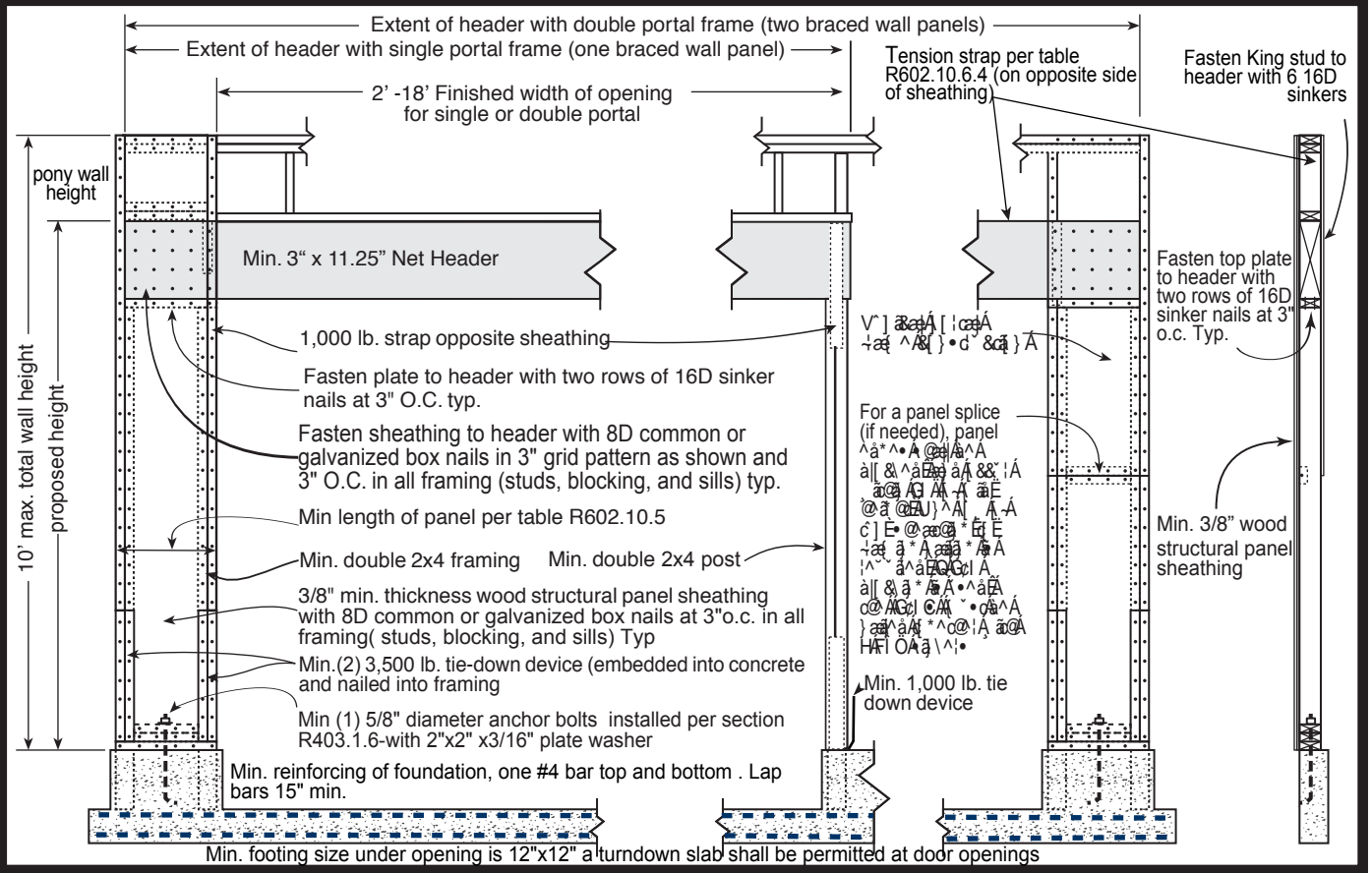

This handout was developed by the Colorado Chapter of the International Code Council as a basic plan submittal under the 2018 International Residential Code. It is not intended to cover all circumstances. Check with your Department of Building Safety for additional requirements.